

Installation Manual



UC5 (Revision 1.6)





ZipRip hardware and software is the property of SMA (Pty) Ltd. Australia
P.O. Box 774, Fyshwick 2609, ACT Australia

This documentation or any part of it may not be reproduced, stored or transmitted in any form, including but not limited to electronic, photocopying, mechanical copying, electrostatic copying, recording or other means without express written permission of SMA (Pty) Ltd. Australia

Windows is a registered trademark of Microsoft Corporation. Macintosh is a registered trademark of Apple Computers Incorporated. Other brand or product names, throughout this document, are trademarks or registered trademarks of their respective holders.

Ricoh and Priport are registered trademarks of Ricoh Japan.



Table of Contents

Introduction	5
Basic Specification	6
Generic Digital Duplicator Driver Groups	7
Package Contents	8
External Features	9
Installing the Video Interface PCB and cabling	10
Video Interface Installation Procedures	11
Video I/F Kit Type 600 Parts List.....	11
Video I/F Kit Type-10, Type-15 and Type- 85 Parts List....	13
Installation Procedures for Interface Kits	14
Model C229, C232 and C233	14
Model C231 and C237	15
Model C238	16
Model C239 and C244	17
Model C210, C218 and C223	18
Model C222	20
Model C226	21
Model C224	23
Cabling Between UC5 and Digital Duplicator	25
Cabling Between UC5 and the Computer	25
Installing the UC5 Hardware	26
Testing the UC5	27
Activity Indicator	29
Troubleshooting GDI	30



Introduction

The UC5 is a high speed interface for Digital Duplicators. With a UC5 you can print directly from your PC to your Digital Duplicator. This will significantly improve the quality of your printed material as well as speed up your printing jobs.

We are confident that you will find it a pleasure to use and an asset to your organisation.

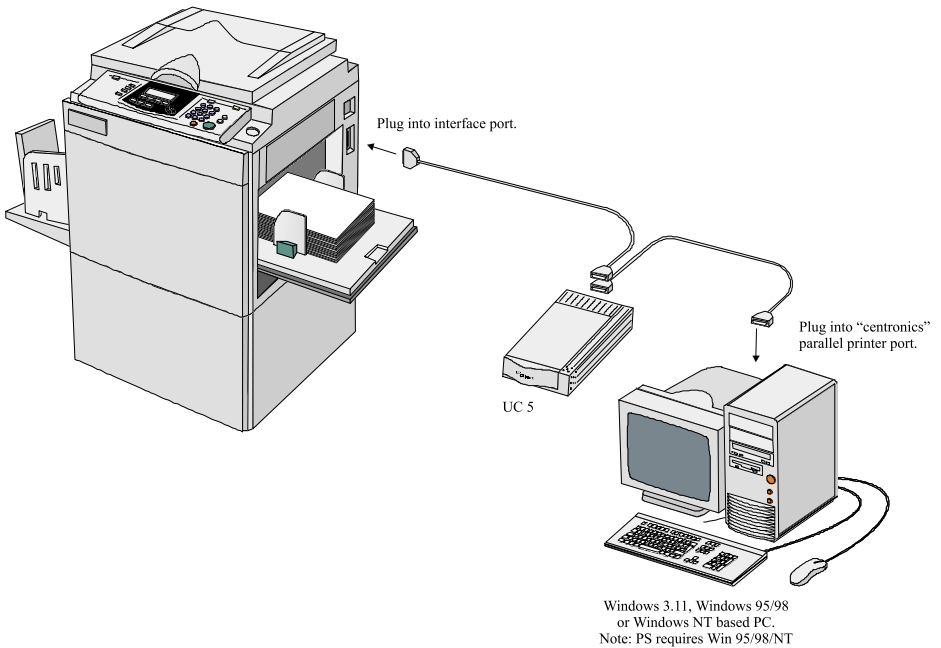



Basic Specifications

- Printer Language: Windows GDI.
- Supported Resolutions: 300, 400 and 600 dpi.
- Graphics Screening: Coarse, Fine, Line Art, Error Diffusion. Density control supported.
- Supported Drivers: Win 3.11, Win 95/98/ME., Win 2000, Win NT
- Ports: ECP/EPP parallel port.
- On Board Memory: 16 MB
- Supported Digital Duplicator
- Brands: Ricoh, Gestetner, Rex Rotary, Nashuatec, Savin and Standard. NB check that your model has interface support.
- Certification: CE, UL, FCC.
230V.

Apparaten skall anslutas till jordat uttag när den ansluts till ett nätverk.

220-240 V, 50/60 Hz Raccordez toujours le cordon d'alimentation à une source de courant correspondant aux normes en vigueur sur le territoire métropolitain.

Branchez le cordon d'alimentation directement à la prise secteur et assurez-vous que cette dernière est reliée à une prise de terre. Veuillez à ne jamais utiliser de rallonge.

The Appliance has to be connected to an earth socket-outlet when the appliance is connected to a Network

This product is also designed for IT power distribution system with phase-to-phase voltage 230V.



Digital Duplicator Driver Groups

Driver Name	Model	Digital Duplicator Model
ZipRIP Classic A	C224	VT2200/5327/1252/CP327/3200DNP
	C226	VT2250/5329L/2546/CP329L/325DNP
	C222	VT2400/5360/1270/CP360
ZipRIP Classic B	C210	VT3500/5375/1280/CP375
	C218	VT3600/5380/1285/CP380
	C223	VT3800/5385/1290/CP385/330DNP
ZipRIP Classic X	C228	VT6000/5390/1295/CP390/3400DNP/SD600
ZipRIP Pro A	C231	JP1010/5306/1224/CP306
	C237	JP1210/5308/1225/CP308
ZipRIP Pro B	C231	JP1030/5306L/1224L/CP306/3150DNP/D300
	C231	JP1050/5306B/1224B/CP306B
	C237	JP1230/5308L/3150eDNP/SD330
	C237	JP1250/5308B/1225B/CP308B
ZipRIP Pro C	C229	JP5000/5450/1560/CP450/3350DNP/SD400
	C239	JP5500/5450/5455/1560/CP450/3360DNP/ SD450
ZipRIP Pro C PT	C232	JP5800/5480/1580/CP480
	C239	JP5500/5450/5455/1560/CP450/3360DNP/ SD450
ZipRIP Pro E	C238	JP3000/5430/1330/CP430/3260DNP/SD370 JP3800/5428C (China)
ZipRIP Pro X	C235	JP8000/5490/1395/CP490/3450DNP/SD630
	C244	JP8500/5490+/5499/1395+/CP490+/ 3460DNP/SD650
ZipRIP Pro X PT	C235	JP8000/5490/1395/CP490/3450DNP/SD630
	C244	JP8500/5490+/5499/1395+/CP490+/ 3460DNP/SD650

*Models with suffix PT indicate additional paper tray unit installed



Package Contents

Check that you have received the following Items in your UC5 package.

Components For UC5.

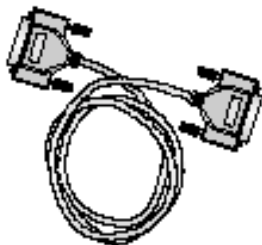

Cable for connecting
to Digital Duplicator

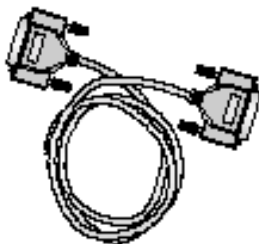

Centronics Parallel
Cable



This User Guide



ZipRIP - UC5

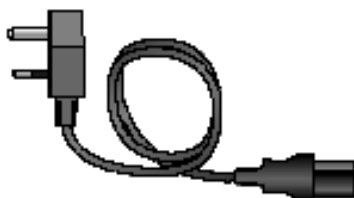

Power Cable

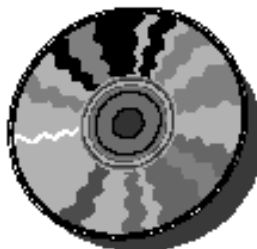

Installation CD



External Features

All indicators and plugs referred to in this manual are described in the diagrams below.

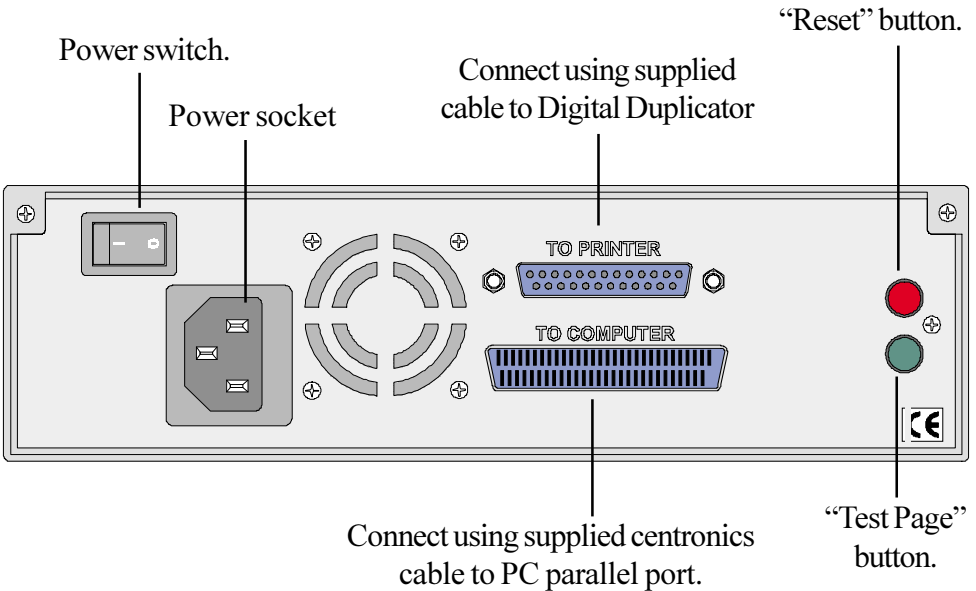
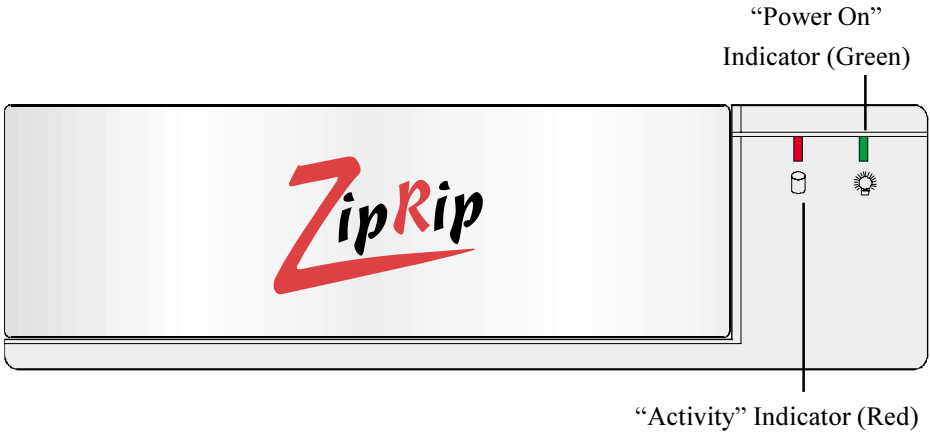



Installation of Video Interface PCB and cabling

NOTE: Video I/F Kit Type- 600, Type- 10, Type- 15, and Type- 85 are Ricoh parts please obtain from supplier.

Before you begin the installation, you should:

- a. Check to make sure that you have all of the items needed to complete a successful installation.
- b. Read the documentation to familiarize yourself with the installation procedures.
- c. Have the following additional items available:
 - Service manual for relevant machine
 - User's Guide
 - A container to hold screws and other removed components
 - Tool Kit



Video I/F Installation Procedures

Video I/F Kit Type-600 Parts List

Common Assemblies

No.	Description	Qty.
1	IC -Interface	1
2	Interface Board	1
3	Insulating sheet -145 -200	1
4	Interface Cable -Interface Board	1

Set for Part 1A

No.	Description	Qty.
5	Stud -50mm	2
6	Spacer -10mm	2
7	PCB Stud -64mm	2
8	Harness Support Bracket	1
9	Phillips Pan Head Screw -M3 x 35	1
10	Phillips Flange Screw -M3 x 8	3
11	Phillips Flange Screw -M4 x 8	3
12	Flat Cable -N810/NA33/NA3/NB2/RN925/N850	1
13	Wire Band	1
14	PCB Collar	1



Set for 1 B

No.	Description	Qty.
15	Flat Cable -NA2	1
16	Main Board Spacer	1
17	Stud -Bracket -Interface	2
18	Interface Board Bracket	1
19	Phillips Screw with Flat Washer -M3 x 25	1
20	Stud -Main Board	1
21	Phillips Screw with Flat Washer -M4 x 6	1
22	Phillips Screw -M4 x 8	2
23	Phillips Screw with Flat Washer -M3 x 6	2

Set for 1C

No.	Description	Qty.
24	Interface Board Stud	2
25	Main Board Stud -Long	4
26	Phillips Screw -M4 x 8	2
27	Phillips Screw with Flat Washer -M3 x 6	4
28	Flat Cable -N865	1



Parts for 1D

No.	Description	Qty.
29	Stud -35 mm	3
30	Phillips Screw with flat washer -M3 x 6	3
31	Phillips Screw -M4 x 8	2

Video I/F Kit Type-10, Type-15 and Type- 85 Parts List

For: Europe, Far East and Asia use Type-10 Interface kit.

For: USA and Latin America use Type-15 Interface kit.

Installation procedure for both Interface kits follow.

No.	Description	Qty.
32	Interface Board	1
33	Relay Harness	1
34	Stepped Screw -M2 x.6	2
35	Tapping Screw -M3 x 6	2



Installation Procedures for Interface Kits

NOTE:

- 1) The UC5 Controller is designed for all Digital Duplicators.
- 2) Numbers in parentheses () in the installation procedures correspond to the part numbers on pages 8 to 10.

Model C229, C232 and C233

Refer to Driver Groups List on page 7

NOTE: The interface kit is required. If the kit is standard you must perform step 3 only to connect the controller .

1. Remove the rear cover and right side panel of the Digital Duplicator.
2. Mount Printed Circuit Board (32) on connector CN102 of the MPU board using two M3x6 screws (35). Mount the cable (33) on the Connector Bracket using two stepped screws (34).
3. Remove the blinding cover in the right side panel.

NOTE:

Select A3 for paper size in initial setting (the default setting is Auto).

The On-line key is enabled automatically when the controller and interface kit are installed.

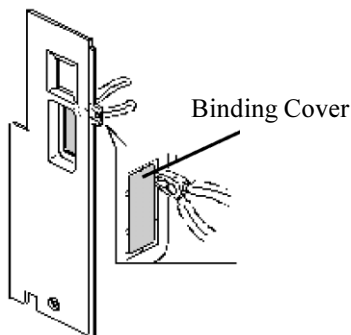
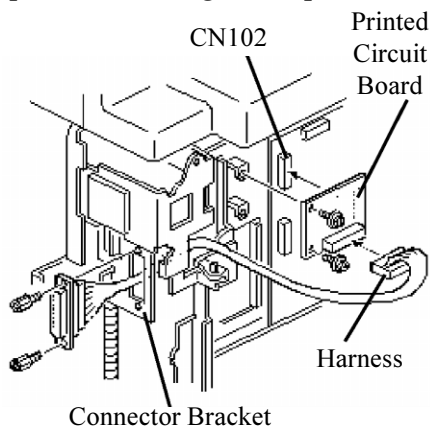



Model C231 and C237

Refer to Driver Groups List on page 7

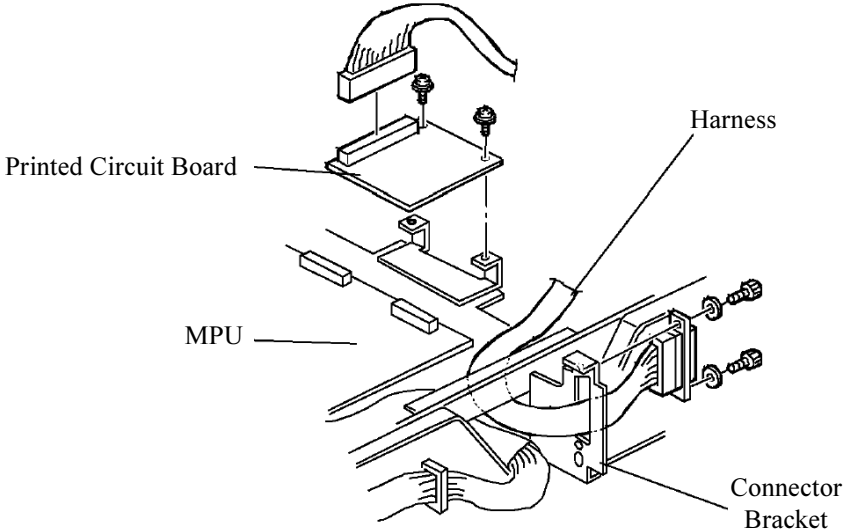

1. Turn off the main switch and unplug the power cord.
2. Remove the upper rear cover.
3. Remove the MPU cover.
4. Connect CN102 of the printed circuit board (32) to CN110 of the MPU board and secure it using two screws (35).
5. Connect the harness (33) to CN101 of the printed circuit Board, and secure it to the connector bracket using two stepped screws (34).
6. Remove the communications port cover plate (blinding cover) from the upper rear cover.
7. Reinstall the MPU cover.
8. Reinstall the upper rear cover.

NOTE:

The On-line key on the operation panel is enabled automatically when the controller and interface kit are installed.



Model C238

Refer to Driver Groups List on page 7

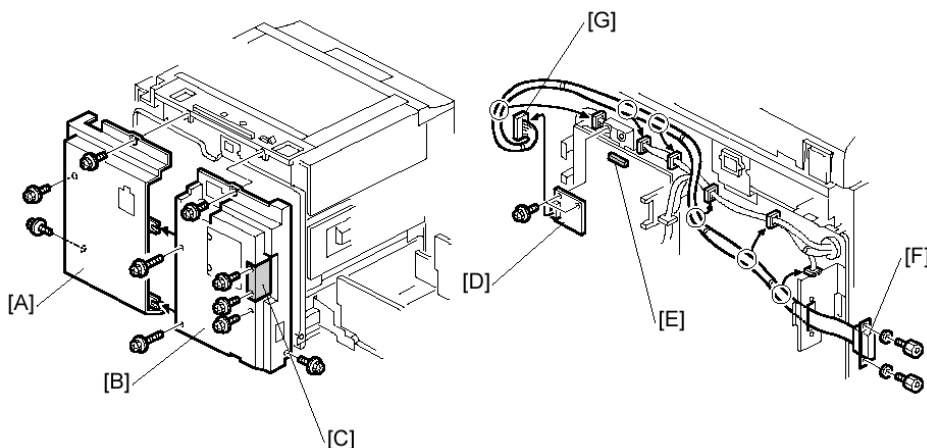

1. Remove the rear covers [A] [B] (8 screws).
2. Remove the I/F connector cover [C] (2 screws).
3. Install the I/F board [D] (accessories) in CN117 [E] on the MPU (2 screws).
4. Attach the cable [F] (accessories) to the connector bracket (2 screws) and clamp the cable (6 clamps).
5. Connect the connector [G] at the opposite end to the I/F board.
6. Re-install the rear covers.



Model C239 and C244

Refer to Driver Groups List on page 7

1. Remove the rear cover [A].

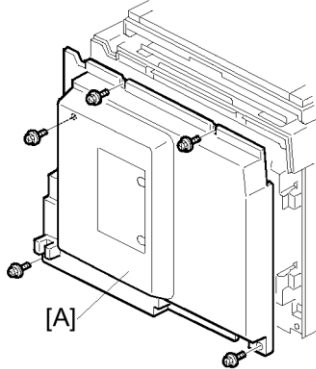

2. Cut away the blindfold cover [B] on the right rear cover.
3. Install the Video I/F board [C] to the MPU. (2 screws)
4. Connect the cable [D] to the Video I/F board. (2 screws, 2 spacers)

NOTE: You need to adjust the length of the harness using the bind [E] enclosed.

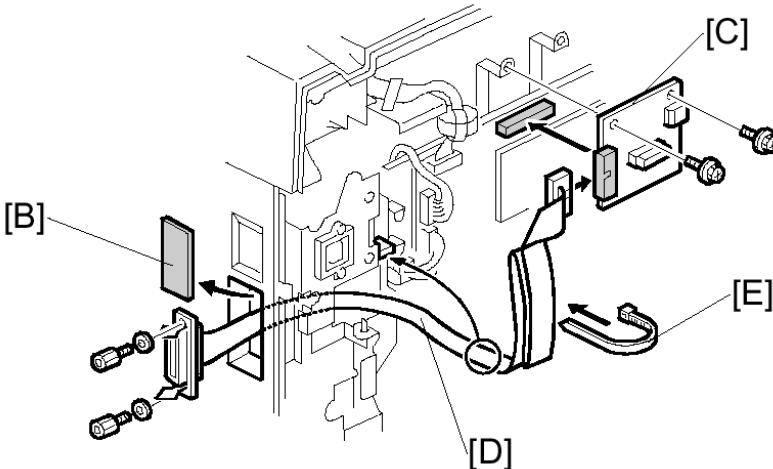

5. Reinstall the rear cover.



Model C210, C218 and C223

Refer to Driver Groups List on page 7

1. Remove the rear cover and front side panel of the Digital Duplicator.
2. Mount the Shielded Cable Interface (2).
 - a) Mount a Stud (17) on the rear chassis of the Digital Duplicator.
 - b) Thread the Shielded Cable (4) from rear chassis to the front chassis under the Digital Duplicator body.

Note for the VT3600/3500/2600: first remove the bottom plate, then reattach it.
 - c) Attach the Shielded Cable (4) on the Stud (17) using two M4x8 Screws (26).

NOTE:

Before mounting Printed Circuit Board Interface (2), attach one end of the Ribbon Cable (12) to the IPU board ribbon cable connector.

3. Mount the Printed Circuit Board Interface (2).
 - a) Mount a Stud (20) on the Digital Duplicator.
 - b) Mount the Bracket (18) on the chassis using a M4x6 screw and washer (21).
 - c) Attach the Printed Circuit Board (2) using 2, M3x6 screws (27). Attach the bottom of the right hand side of the Printed Circuit Board to the Spacer (16) using a M3x25 screw (19).
 - d) Attach the connector of the Printed Circuit Board (2) to the Shielded Cable (4).
 - e) Attach free end of the Ribbon Cable (21) to the Printed Circuit
 - f) Board Interface (2).

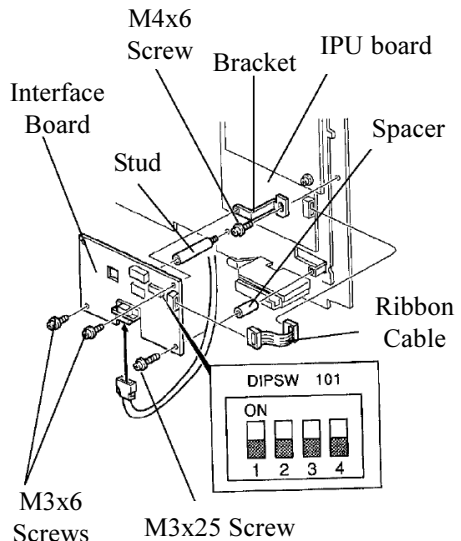



4. Set the Printed Circuit Board interface switches.
 - a) Set all switches on DIPSW 101 to OFF.
5. Reattach the side cover panels of the Digital Duplicator.
 - a) Pop out the communication port cover plate from the lower centre of the rear cover panel.
 - b) Reinstall the rear and front cover panels.

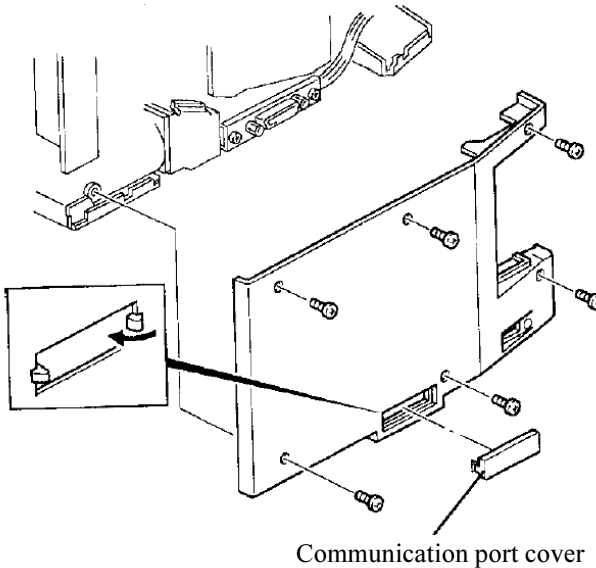

6. Connect the Digital Duplicator and AC power to the Controller.
 - a) Connect a Video Cable between the Digital Duplicator and the Controller.
 - b) Connect an AC cable to the Controller.
7. Set SP Mode 1 (for the On-line Key On/Off) to ON.



Model C222

1. Remove the rear cover and front side panel of the Digital Duplicator.
2. Mount Shielded Cable Interface (4).
3. Mount Printed Circuit Board Interface (2).
 - a) Remove the three screws attaching the mainframe MPU Board to the chassis (two screws upper and lower side of CN109, and one screw lower side of the CN111).
 - b) Replace the screws removed in a) above with Studs (29).
 - c) Connect one side of the Ribbon Cable (12) to the connector of Mainframe MPU Board.
 - d) Attach the Printed Circuit Board Interface (2) to the Studs (29) using M3x6 Screws (27).
 - e) Connect the free end of the Ribbon Cable (12) to the CN102 connector of Printed Circuit Board Interface (2).
 - f) Set all switches of DIPSW 101 on the Printed Circuit Board Interface (2) to OFF.
4. Pop out the communication port cover plate from the lower centre of the rear cover panel. Reinstall the rear and front cover panels.
5. Set SP Mode 2-1 (On-line Key On/Off) to ON.

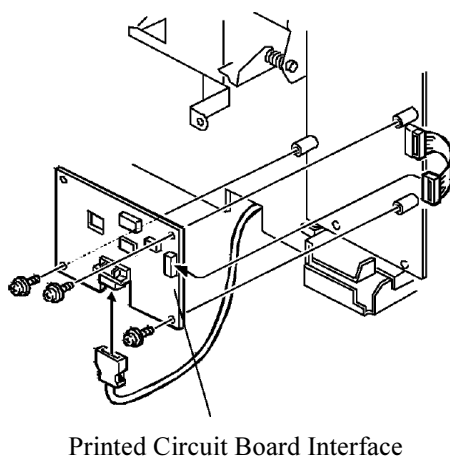
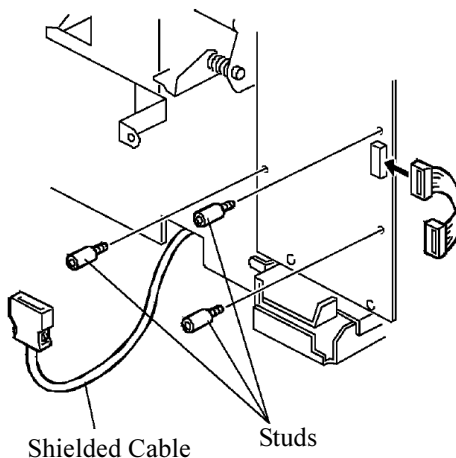



Model C226

1. Remove the top cover of the Mainframe MPU Board.
2. Remove screws attached to the two studs on the top of MPU Control Board.
3. Connect the free end of the Ribbon Cable (12) to the connector marked CN110 located at the left edge of the MPU Control Board.
4. Position the MPU Control Board and Printed Circuit Board Interface (2) on the Studs.
5. Attach the Printed Circuit Board Interface (2) to the MPU Control Board, taking care to align the left edge with the locking spacers.
6. Attach the right side edge of the Printed Circuit Board (2) to the mounting Studs on the MPU Control Board using three M3x6 screws.
7. Connect the free end of the Ribbon Cable (12) to the connector marked CN102 on the Printed Circuit Board Interface (2).
8. Attach the Shielded Cable to the Printed Circuit Board Interface (2).

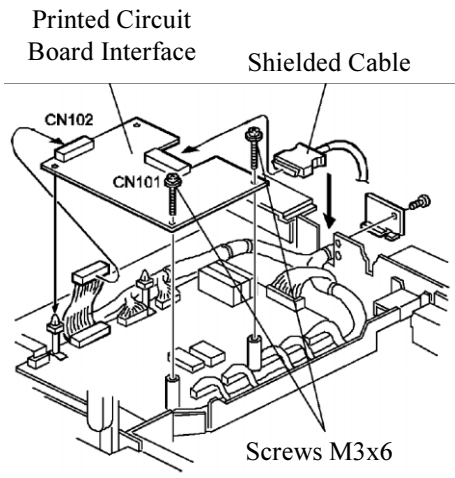
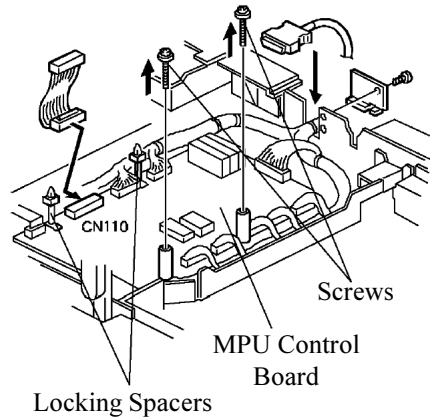



9. Remove the rear cover panel of the Digital Duplicator.
10. Remove the Plate attached to the channel for the Main Harness in the rear upper of the Chassis.
11. Route the Shielded Cable (4) along side the Main Harness.
12. Reattach the Plate.
13. Mount the Studs (24) on the rear chassis of the Digital Duplicator.
14. Mount the Bracket end of the Shielded Cable (4) onto the Studs (24) using two M4x8 screws (26).
15. Tie the Shielded Cable (4) to Main Harness using the Tie Band (13).
16. Pop out the communication port cover plate from the lower centre of the rear cover panel.
17. Reinstall the rear cover panel of the Digital Duplicator.
18. Set all switches on DIPSW 101 of the Printed Circuit Board Interface (2) to OFF.
19. Reinstall the top cover of the Digital Duplicator.
20. Set SP Mode 1 (Online Key On/Off) to ON.

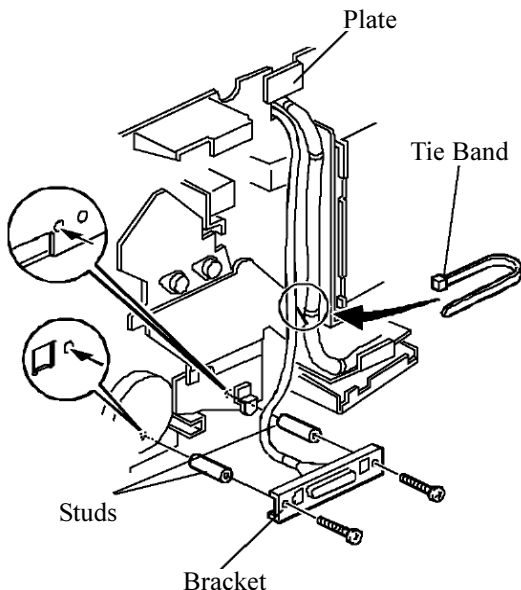



Model C224

1. Remove the rear and front covers of the Digital Duplicator.
2. Mount Shielded Cable Interface (4).
 - a) Mount two Studs (24) on the rear chassis of the Digital Duplicator.
 - b) Remove bottom plate of the Digital Duplicator.
 - c) Thread the Shielded Cable (4) from the rear chassis to the front chassis under the Digital Duplicator body.
 - d) Reinstall the bottom plate.
 - e) Mount the Bracket of the Shielded Cable (4) on the Studs (8) using two Phillips Screws M4x8 (26).

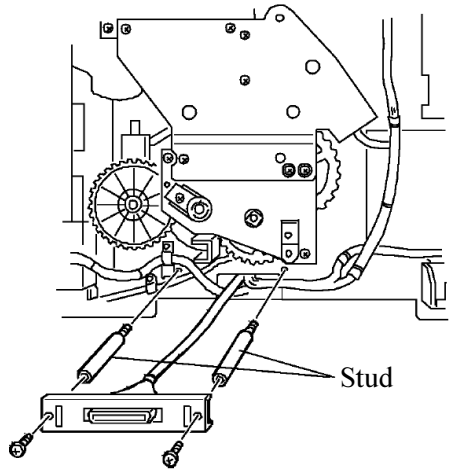

3. Mount Printed Circuit Board Interface (2).
 - a) Mount four Studs (25) on the front chassis of the Digital Duplicator.
 - b) Connect the Ribbon Cable (12) to the MPU board of the Digital Duplicator.

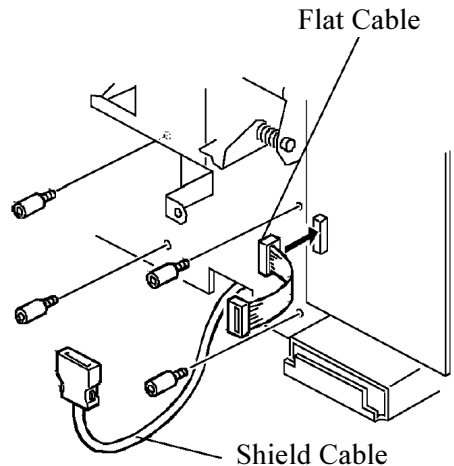



- c) Attach the Printed Circuit Board Interface (2) to the Studs (25) using four M3x25 Screws (20).
 - d) Connect the free end of the Ribbon Cable (27) to CN102 of the Printed Circuit Board Interface (2).
 - e) Connect the Shielded Cable (4) to CN101 of the Printed Circuit Board Interface (2).
 - f) Set all switches on DIPSW 101 of the Printed Circuit Board Interface (2) to OFF.
 - g) Set DIPSW 103-8 of the Mainframe MPU Board (Online On/Off) to ON.
4. Pop out the communication port cover plate from the lower centre of the rear cover panel.
 5. Reinstall the rear and front cover panels of the Digital Duplicator.

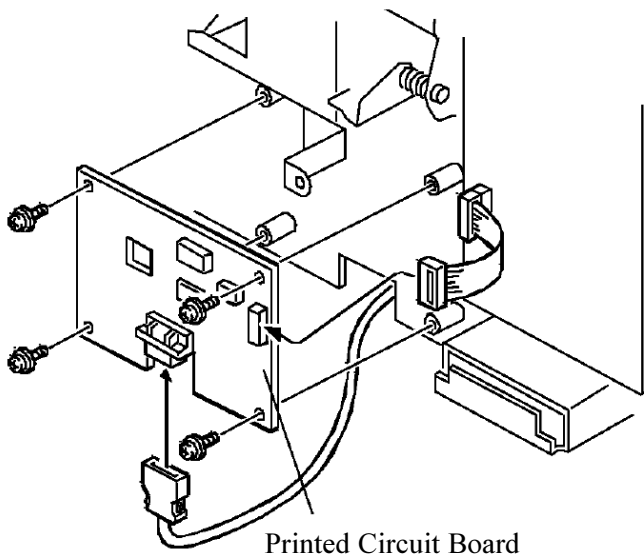



Cabling between UC5 and Digital Duplicator

1. Attach the end of the cable provided, to the communications port that has been installed in the Digital Duplicator
2. Attach the other end of the cable to the port on the rear of the UC5 labelled “To Printer ”.

Cabling between UC5 and the Computer

IBM and Compatibles -Parallel

1. Make sure that the customer’s computer is turned off.
2. Attach the DB25 end of the Centronics parallel cable to the customer designated parallel output port on the rear of the computer. Record the choice of port, because this port name will be required during the configuration process.
3. Attach the other end of the Centronics parallel cable to the input port on the rear of the UC5 labelled “To Computer ”.



Installing the UC5 Hardware

This installation should take 15 minutes excluding the time taken to install the video board.

NOTE:

1. Check that the Digital Duplicator you are using supports an interface.
2. Many Digital Duplicator models do not have the interface option as standard. Please ensure that the interface option for your Digital Duplicator has been installed prior to installing the UC5.
3. When installing the UC5 on Model C238 Digital Duplicator, do not install the rubber paper guides on the paper tray.

1. Remove your UC5 and ancillary cables from the box. Ensure the Digital Duplicator is turned off.
2. Attach one end of the long parallel cable supplied to the Digital

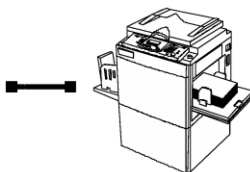

To Printer

Duplicator interface port. Attach the other end of the same cable into the port marked “To printer”.

3. Attach the DB25 end of the Centronics parallel cable to the customer designated parallel output port on the rear of the computer. Attach the other end of the Centronics parallel cable to the input port on the rear of the UC5 labelled “To Computer”.

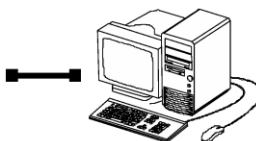

To Computer



4. Connect up the mains power using the supplied cable. Switch on the power and turn the UC 5 on. The green “power on ”indicator should be lit. The red “activity ”indicator should light briefly when the unit is powered up. (6 seconds)

Turn the Digital Duplicator on next.

The diagram below illustrates how the UC 5 should be connected.

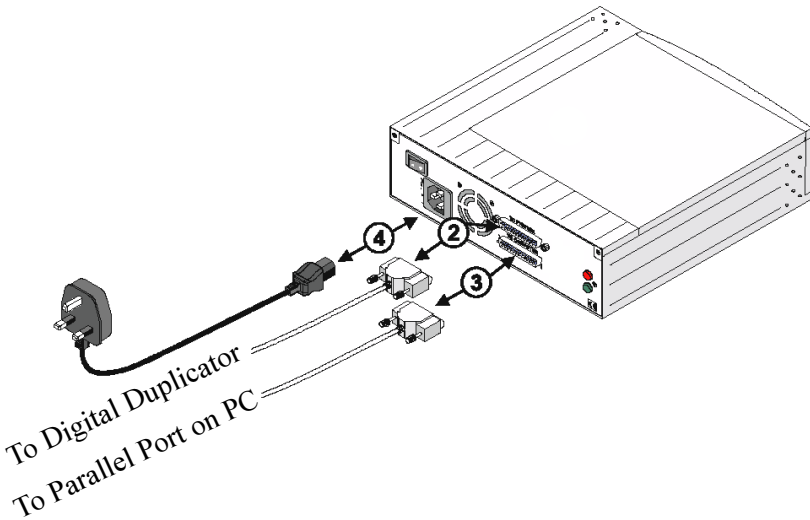

Testing your UC5

Once you have set up the UC5 as described above, you can produce a test page before continuing to install the printer drivers on your computer. (See Operators Manual for UC5)

To produce a test page, put your Digital Duplicator “on-line ”and press the green button at the back of the UC5.



After a short delay a test page should be printed. The test page should look like the illustration below.

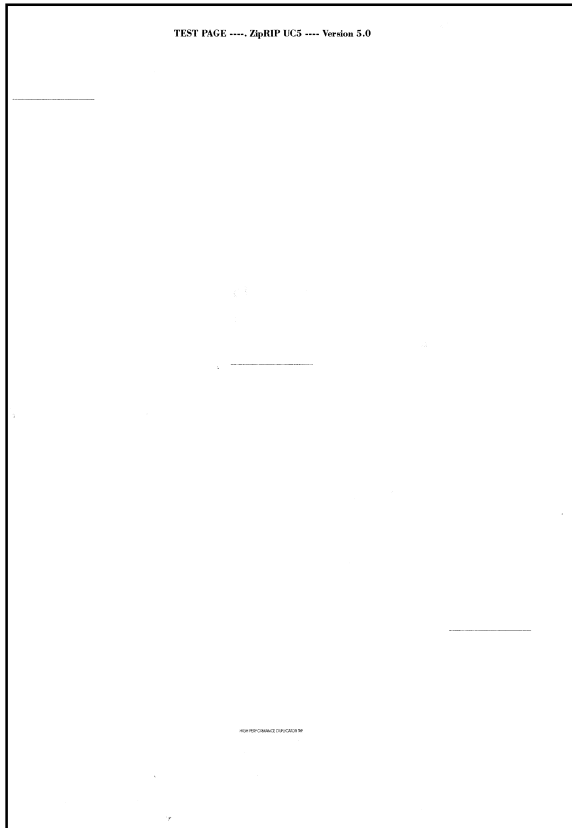

NOTE:

The test page will print as an A4 sheet on a 300dpi Digital Duplicator. If the Digital Duplicator has a higher resolution then the output will appear smaller. -This is normal.

If a test page is not created correctly, then refer to the section: “Troubleshooting your UC 5”.



Activity Indicator

The red activity indicator shows the status of the UC 5. The table below explains the different status indications.

Red Indicator Display	Meaning
On just after the UC5 is turned on.	UC5 initializing - the red light will stay on for 6 seconds.
Flashing rapidly.	The UC5 is receiving a print job.
Continuously on.	The UC5 has received a print job and is now waiting.
Continuously off.	The UC5 is idle.
Flashing slowly and evenly.	There is an error on the digital duplicator, such as paper jam.



Troubleshooting UC5

Normally, your UC5 will function correctly with no user intervention. If there is a problem use this section as a guide to solve it.

Problem: The following message is printed when I try to print a document: There was an error writing to LPT1: for the printer... The printer is not ready. Make sure it is turned on and on-line.

Try the following:

- a) Check all physical cable connection and power.
- b) Reset the UC5.
- c) Check you are not trying to print to the UC5 across a network. If this is the case see your windows documentation on network printing.
- d) Check the parallel port is set to “ECP” mode.

Problem: Print jobs download to the UC5, but the Digital Duplicator does not create a master.

Try the following:

- a) Press the Digital Duplicator “on-line” key. Some Duplicators do not support Auto on-line functions. Check that your Duplicators Auto on-line function has been enabled. Check also that the last print run on the Digital Duplicator has been completed.
- b) Turn the Digital Duplicator off then on.

Problem: Activity light on the UC5 is permanently on, but no master is created.

Try the following: Press the reset button on the UC5.

Problem: UC5 connected via optional network interface does not respond.

Try the following:

- a) Reset the network interface.
- b) Check connections to the network interface.
- c) Make sure that the configuration for the network interface port is referencing the correct network interface.



If none of the above resolves your problem you can send a description of the error to the ZipRip web site. Please include all details such as PC specification, Operating System, Application and version being used as well as a detailed account of the error and any preceding events that might have led to it. **www.ziprip.com**